



2010 FLL CHALLENGE

ROBOT GAME – FIELD SETUP

OVERVIEW

- The field is where the Robot Game takes place.
- It consists of a field mat, on a table, with mission models arranged on top.
- The field mat and the LEGO pieces for building the mission models are part of your Field Setup Kit.
- The instructions for building the mission models are on a CD, in the same box as the LEGO pieces.
- The instructions for how to build the table and how to arrange everything on it are here...

TABLE CONSTRUCTION

The Robot Game takes place on a specially designed table, so you'll need to build one to practice on if you don't already have access to one. With safety, weight, height, and cost in mind, a simple design is offered here, but as long as your surface is smooth, and your border walls are located properly, how you build the understructure is up to you. The construction is simple, but does require some wood-working skills.

At a tournament, two tables are placed back to back, but you only operate on one table, so you only need to build one table to practice on. Since a tournament setup has a double wall at the interactive area where the two tables meet, practice tables need an extra wall of type **B** on the corresponding side. So here are the instructions for building one "half-table" including a double north wall:

MATERIALS

Material	Quantity
Field Setup Kit (mission model LEGO elements, mat, CD, Dual Lock)	1
sanded plywood (or other very smooth board) 96" X 48" X 3/8" or thicker = 2438mm X 1219mm X 10mm or thicker	1
two-by-four, 8' (actual cross-section = 1-1/2" by 3-1/2") = long board, 2438mm X 38mm X 89mm	4
two-by-three, 8' (actual cross-section = 1-1/2" by 2-1/2") = long board, 2438mm X 38mm X 64mm	2
flat black paint	1 pt. (half liter) or spray can
coarse drywall screws, 6 X 2-1/2" = coarse drywall screws, ~64mm long	1/2 lb. or 227g
saw horses, about 24" high and 36" wide = 610mm high and 914mm wide	2

PARTS

Part	Make From	Dimensions	Paint	Quantity
table surface (A)	Plywood	96" X 48" 2438mm X 1219mm	no	1
long border wall (B)	two-by-four long board	96"2438mm	yes	3
short border wall (C)	two-by-four	45" 1143mm	yes	2
stiffener (D)	two-by-three	48" 1219mm	no	4
saw horse	purchase	H ~ 24" W ~ 36" 610mm 914mm	no	2

ASSEMBLY

Step 1 - Determine which face of the plywood (A) is least smooth, and consider that the bottom face. On the bottom face, locate, clamp, and screw on the stiffeners (D) (about every 18 inches). Be sure screw head tops are flush. Sand any splinters.

Step 2 - On the top face of the plywood, locate, clamp, and screw on the border walls (B,C) around the top perimeter. The wall-to-wall dimensions must measure $93\pm 1/8"$ by $45\pm 1/8"$ ($2362\pm 3\text{mm}$ by $1143\pm 3\text{mm}$).

Step 3 - With the help of another person, place this table top on short saw horses (or milk crates, or anything else short and solid).

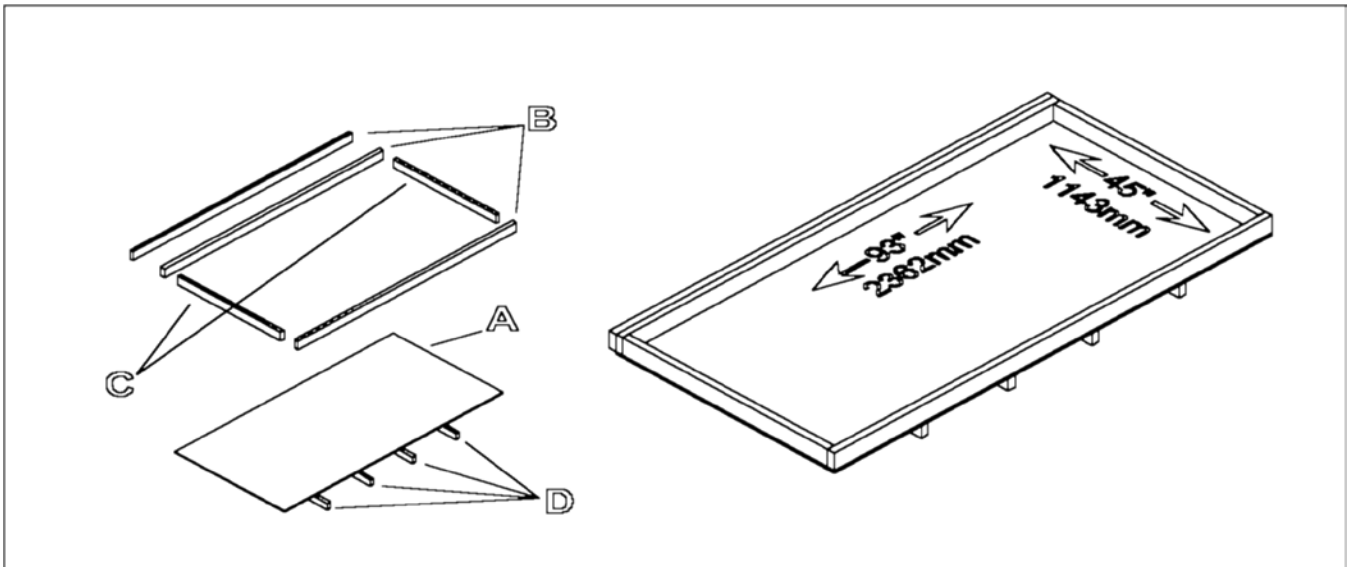

FIELD MAT PLACEMENT

Step 1 - Vacuum the table top. Even the tiniest particle under the mat can give the robot trouble. After vacuuming, run your hand over the surface and sand or file down any protruding imperfections you find. Then vacuum again.

Step 2 - On the vacuumed surface (never unroll the mat in an area where it could pick up particles), unroll the mat so the image is up and its north edge is near the north/double border wall (note the location of the double wall in each table sketch below).

Step 3 - The mat is smaller than the playing surface by design. Slide and align it so that there is no gap between the south edge of the mat and the south border wall. Center the mat in the east-west direction (look for equal gaps at left and right).

Step 4 - With help from others, pull the mat at opposite ends and massage out any waviness away from the center and re-check the requirement of Step 3. It is expected that some waviness will persist, but that should relax over time. Some teams use a hair dryer to speed the relaxation of the waviness.

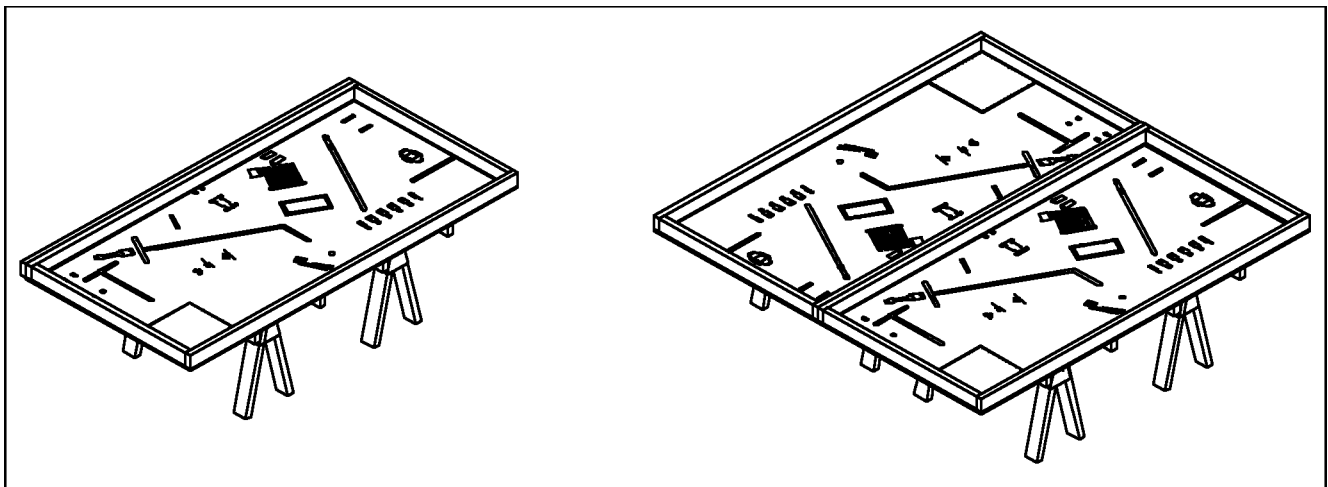
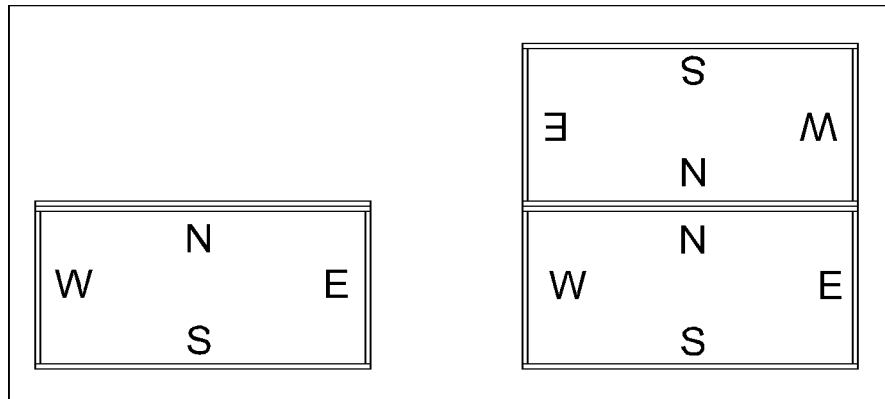

MISSION MODEL CONSTRUCTION

Build the mission models - Use the LEGO elements and instruction CD from your Field Setup Kit. It should take a single person between two and three hours to do this, so it's best done in a work party. If there are any team members with little or no experience building with LEGO elements, mission model construction is a great way to learn. This step is also a nice time for new team members to get acquainted with each other.

MISSION MODEL ARRANGEMENT

DUAL LOCK

For models where "Dual Lock Needed" appears in the mission model details below, that means the model needs to be secured to the mat during use. The connection is made using the re-usable fastening material from 3M called Dual Lock, which comes in the flat clear bag with the LEGO elements in your Field Setup Kit. Dual Lock is designed to stick or "lock" to itself when two faces of it are pressed together, but you can unlock it too, for ease of transport and storage. The application process for the Dual Lock is only needed once. Later, the models can simply be locked onto the mat or unlocked. To apply Dual Lock:

Step 1 - Stick one square, adhesive side down, on each box you see on the mat with an "X" in it.

Step 2 - Press a second square on top of each of those, "Locking" them on, adhesive side up. TIP: Instead of using your finger, use a bit of the wax paper the squares came on.

Step 3 - Lower the model onto the squares.

CAUTION - Be sure to place each square precisely on its box, and each model precisely over its marks.

CAUTION - When pressing a model down, press down on its lowest solid structure instead of crushing the whole model. Pull on that same structure if you later need to separate the model from the mat.

TIP: For large/flexible models, apply only one or two sets at a time.

MODEL DETAILS

Artery - Dual Lock Needed - Position this model perfectly on its mark at the northwest of the field.

Ramp - Dual Lock Needed - Position this model perfectly on its mark at the northwest of the field, with the low end toward Base. There are no other instructions or cautions for it.

Syringe - (NO Dual Lock Needed) - Place red and white blood cells in the order shown below (from the low end: white, red, white, two red, white, two red, then 2x3 open space). Then lift the ramp's lever as far as it will go. The park the syringe at the high end of the ramp, so the red stopper keeps the syringe from rolling. Then be sure the west wheels are both touching the red railing. Be sure to tighten the syringe's body pieces once in a while, especially the needle.

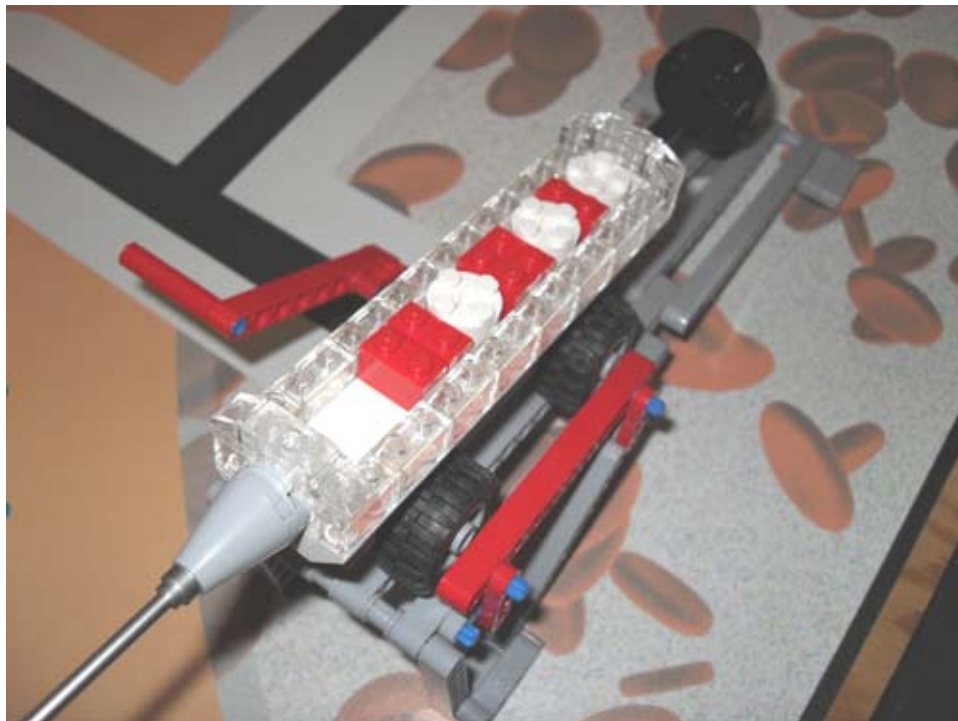

Small Bone - Dual Lock Needed - Position the smaller (west) side part of this model perfectly on its mark at the west center. Then position the bigger (east) side over its mark, and press it down such that there's a 1/16" in (1.5 mm) gap between the two parts. Set position is with the east part angled to line up with the angled lines under it.

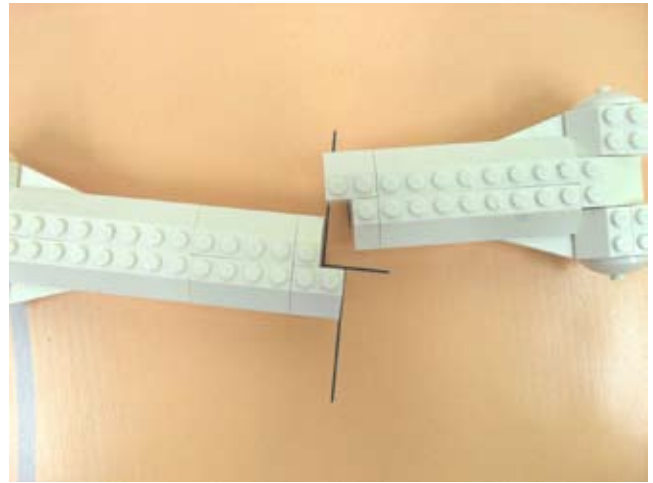
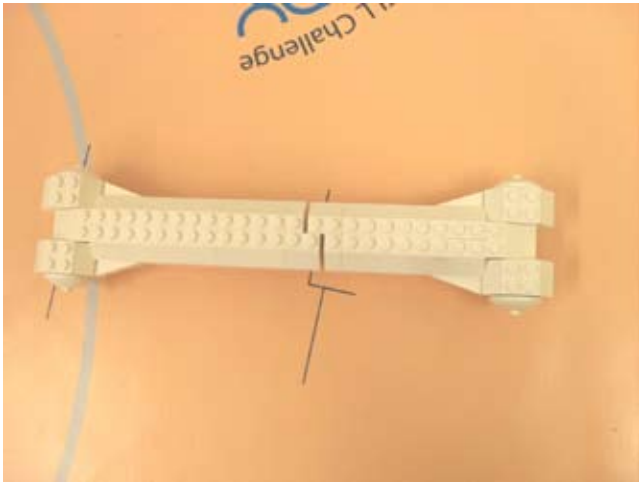

Large Bone - Dual Lock Needed - (for the big part, but not the small part) - Position the bigger part of this model perfectly on its mark at south center. The set position is with the smaller part positioned as shown, with both parts pressed against the gray rail for alignment, and a 1/16" in (1.5 mm) gap between them. Place the blue ball on the black ring, near the foot.

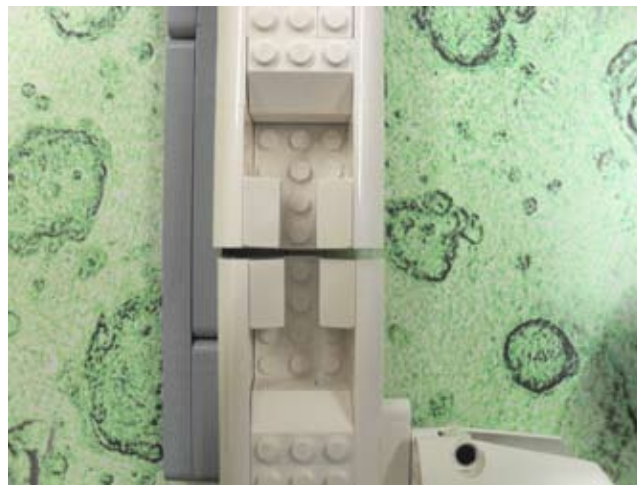

Goal - Dual Lock Needed - Position this model perfectly on its mark at the field's center, with the green strip facing south southwest.

Tissue Areas (Bad and Good Cells) - Dual Lock Needed - Position this model perfectly on its mark at southeast center. The set position is with all panels vertical and each randomly flipped showing white or black. Exception: You will never encounter a setup with all black facing north. This model is set while the robot is active, outside Base. This way you never know what the combination is while the robot's in Base.



Brain And Door - Dual Lock Needed - Position this model perfectly on its mark at the east. Be sure the axle connecting the brain to the door runs parallel with the ground. Set position is with the door all the way closed.

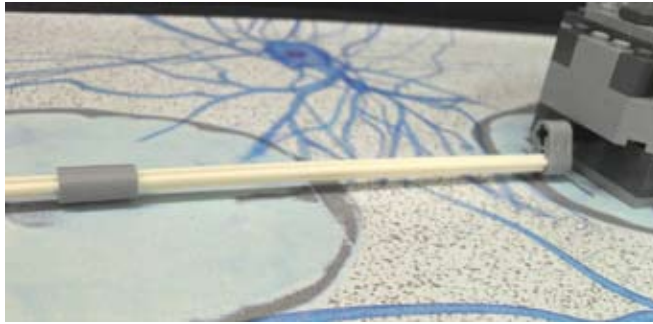

Pressure Tester - Dual Lock Needed - Position this model perfectly on its mark at the northeast. Set position is with the wheel weight all the way down. Be sure the rubber belt runs only in the groove of the gray half-bush (tiny pulley). The belt must not be allowed to rub on the blue beams nor the tan cross-axle. The more friction there is in this model, the easier the mission seems - so be sure you're practicing with a properly maintained model, because they're likely to be correct at tournaments.

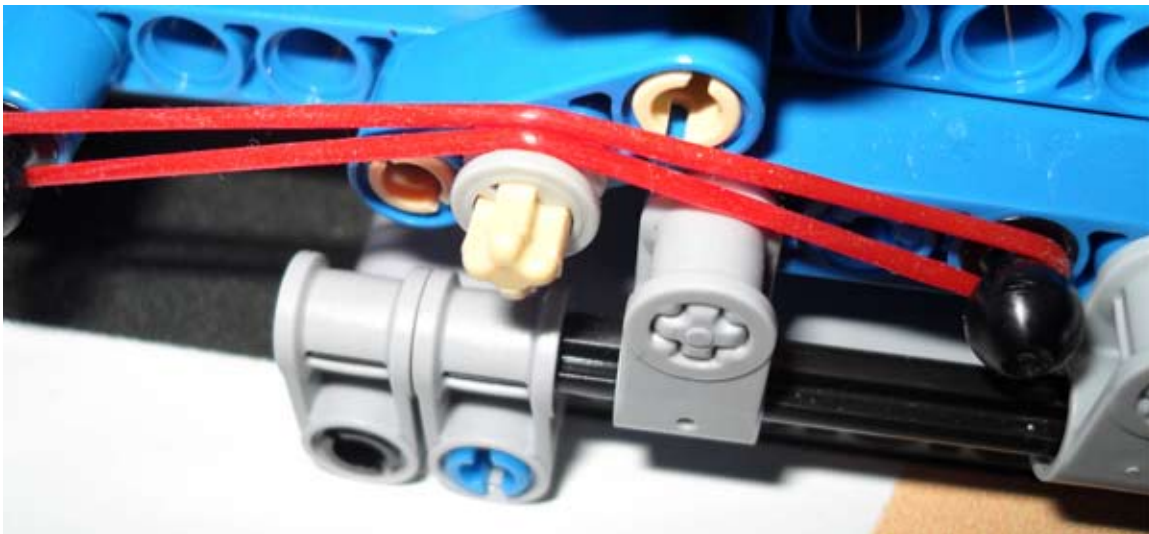

Doctor And Patient - (No Dual Lock Needed) - Position the doctor on the center of the directional compass at the northwest, sitting, looking toward Base. Position the patient on the nucleus of the west-most nerve cell, sitting, looking west. There is no set position for the people's arms, and the doctor's case may or may not be present. Each person's hair must look great.



Medicine Dispenser And Container - Dual Lock Needed (for the dispenser, but not the container) - Position these models perfectly on their marks at the northeast center, with the dispenser's black panel facing east southeast. Set position is with the black panel all the way out, and with medicine arranged in columns. The east column pink, center column white, and west column blue. The medicine does not need to be aligned to itself, or to the dispenser, or crowded in any direction, as long as it all fits reliably on its shelf.



Mechanical Hand - Dual Lock Needed - Position this model perfectly on its mark at the north center, with the hand facing north. Set position is with the hand low and pulled back. It's easiest to set the hand while the patent is not set. Push the arm's base (red forearm) as far north as it will go, then rotate the arm toward the mat as far as it will go. Finally, without letting the arm rotate, slide it south as far as it will go.

Patent - Dual Lock Needed - This model rests half on your field and half on the other team's field. If you only have one field to practice on (most teams only have one), that means two of this model's feet will dangle loosely in the air unless you build something for those feet to rest on. For the gray frame, position the two feet on your field on their marks, perfectly east vs. west, but it's okay and expected if the north vs. south placement isn't exactly on the marks. The hand will grab the patent from a variety of distances. Then place the patent in the holder.

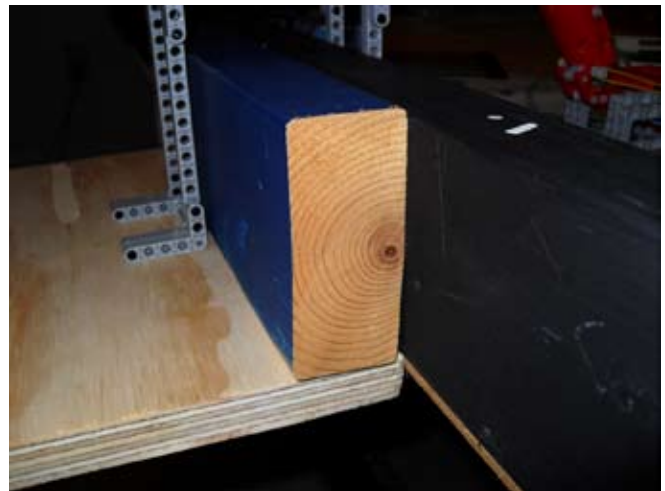
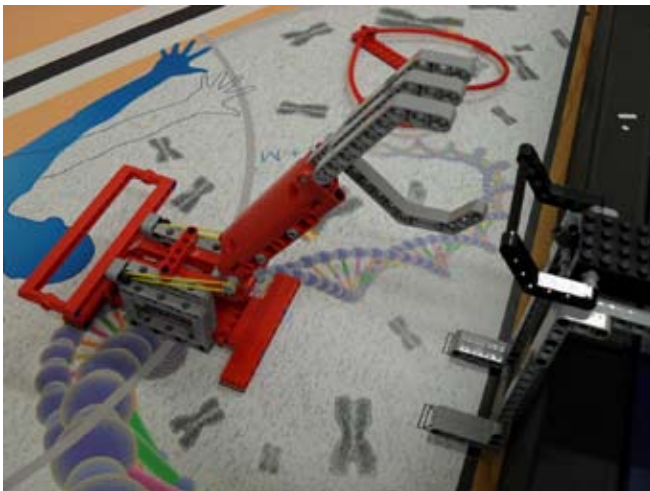

Heart - Dual Lock Needed - Position this model perfectly on its mark at the north west center, with the point facing south southwest.

Remaining Models - (No Dual Lock Needed) - Place both bionic eyes, the stent, three red blood cells, the pace maker, the cast, the biomedical engineer, the cardiac patch, and the bone bridge anywhere in Base, or in your team supplied box in view of the referee.



FIELD MAINTENANCE

- Border Walls - Remove any obvious splinters, and cover any obvious holes.
- Field Mat - Make sure the mat touches the south border wall, and is centered east to west. Avoid cleaning the mat with anything that will leave a residue. Any residue, sticky or slippery, will affect the robot's performance compared to a new mat (many tournaments use new mats). Use a vacuum and/or damp cloth for dust and debris (above and below the mat). To get marks off, try a white-plastic pencil eraser. When moving the mat for transport and storage, be sure not to let it bend into a sharp kink point, which could affect the robot's movement. Tournaments using new mats should unroll the mats as far in advance of the tournament day as possible. For control of extreme curl at the east or west edges of the mat, tape is allowed, with a maximum of $\frac{1}{4}$ " (6 mm) overlap. Foam tape is not allowed.
- Mission Models - Keep the models in original condition by straightening and tightening solid connections often. Ensure that spinning axles spin freely by checking for end-to-end play and replacing any that are bent.